

产品特点 and 用途 Description of the product

出轴直径为 12mm, 出轴长度为 37mm 的滚珠轴承型齿轮减速器, 减速比为 1: 3,
使用电源为 220V/50HZ,
可带附加功能: Z-机械阻尼、P-热保护器、刹车、调速器。

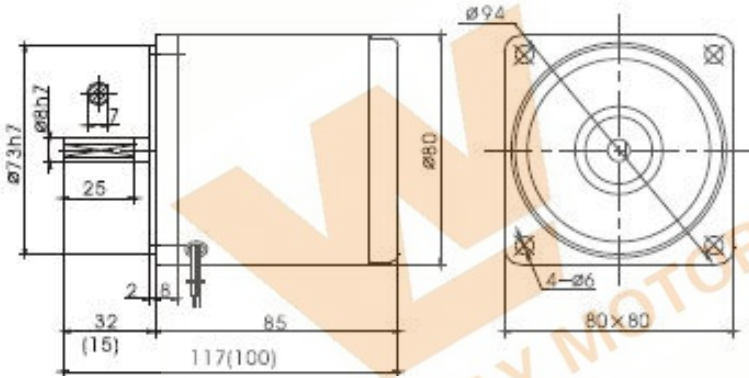

电机外形尺寸 Motor Overall Dimension



接线图 Wiring Diagram

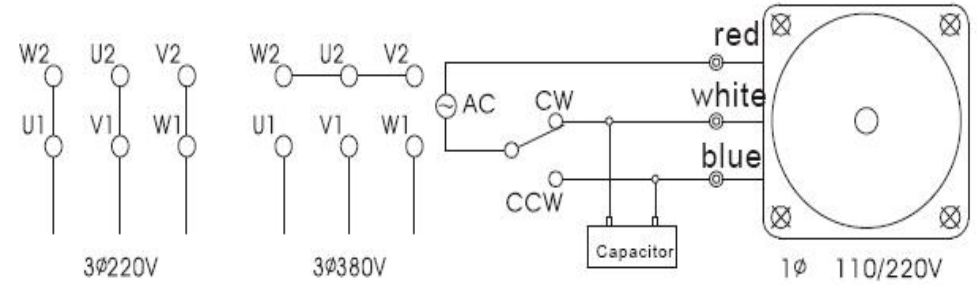

电机特性表 List of motor Characristics

电机型号 Model of Motor		出力 Output	电压 Voltage	频率 Frequency	极数 Poles	额定时间 Duty	额定 Rated				启动扭矩 starting torque		电容电量/耐压 capacitor/V
光电机 Motor	带齿轴电机 Motor with gearshaft	W	V	Hz	P		转速 speed	电流 current	力矩 torque		N.m	Kgf.cm	μ F/VAC
							r/min	A	N.m	Kgf.cm			
6IK140A-AF	6IK140GU-AF	140	1ph110	50	4	连续 cont	1350	2.00	0.99	9.95	0.90	9.00	3.0/250
6IK140A-CF	6IK140GU-CF	140	1ph220	50	4	连续 cont	1350	1.13	0.99	9.95	0.90	9.00	10.0/450

齿轮箱允许力矩 Allowable Torque on Gearbox

齿轮箱形式 Model of Gearbox:6GU□K

频率 frequency	减速比 Reduction Ratio		3	3.6	5	6	7.5	9	10	12.5	15	18	20	25	30	36	40	50	60	75	90	100	120	150	180	200
50Hz	输出轴转速 Output Shaft Speed	r/min	500	417	300	250	200	166	150	120	100	83	75	60	50	41	37	30	25	20	16	15	12	10	8	7.5
	允许力矩 Allowable Torque	N.m	2.36	2.83	3.93	4.71	5.89	7.07	7.07	8.85	10.6	12.7	12.7	16.0	19.2	23.0	25.6	32.0	38.4	39.2	39.2	39.2	39.2	39.2	39.2	39.2
kgf.cm		24.1	28.8	40.1	48.1	60.1	72.1	72.1	90.3	108	130	130	163	196	235	261	327	392	400	400	400	400	400	400	400	400
60Hz	输出轴转速 Output Shaft Speed	r/min	600	500	360	300	240	200	180	144	120	100	90	72	60	50	45	36	30	24	20	18	15	12	10	9
	允许力矩 Allowable Torque	N.m	2.03	2.44	3.39	4.06	5.08	6.09	6.09	7.6	9.15	11.0	11.0	13.8	16.6	19.9	22.1	27.6	33.1	39.2	39.2	39.2	39.2	39.2	39.2	39.2
kgf.cm		20.7	24.9	34.6	41.2	51.8	62.1	62.1	77.6	93.4	112	112	141	169	203	226	282	338	400	400	400	400	400	400	400	400

齿轮箱外形尺寸 Overall Dimension of Gearbox

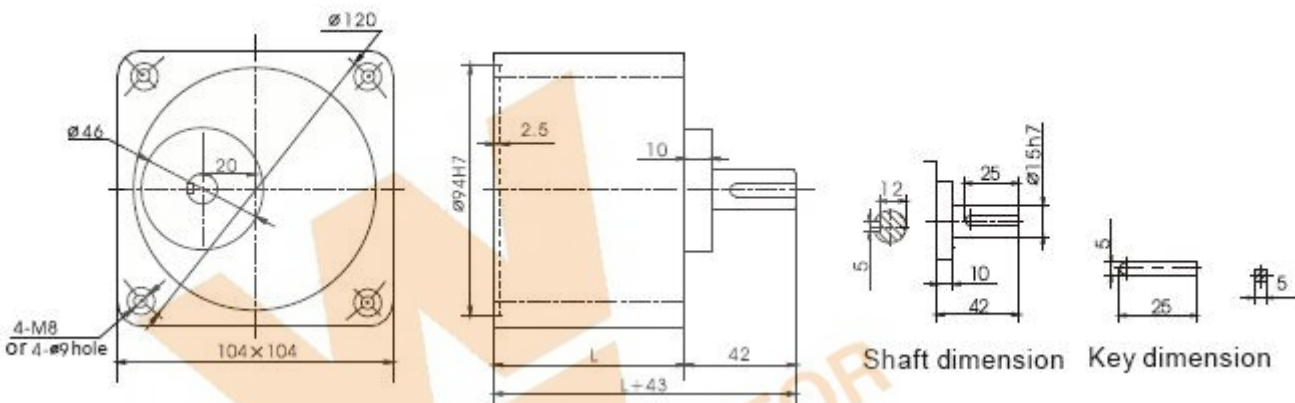

	Reduction Ratio	Size L (mm)	Weight (Kg)
Gearbox	6GU3K-GU9K	72	1.87
	6GU10K-GU18K	72	2.10
	6GU20K-GU200K	72	2.75
Motor			5.05

电容器 Capacity

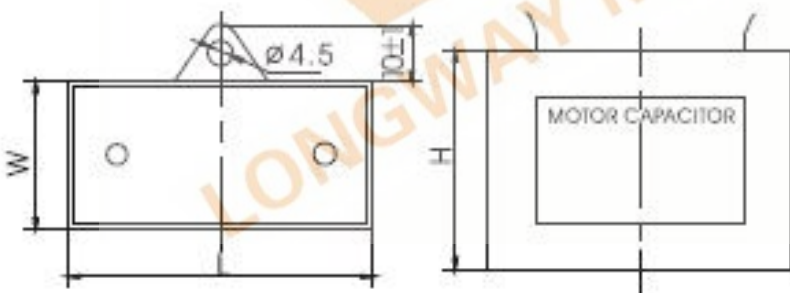

Capacitor	Voltage	Length	Wide	High	Type
μ F	V	mm	mm	mm	
10.0	450	47	26	38	Down-lead
30.0	250	68	32	56	